



EQUIPAGGIAMENTI  
TECNICI  
LAVAGGIO

26.1420.00  
GR 38/200

I  
GB

4

12.9426.00 28/11/08

## CARATTERISTICHE TECNICHE – SPECIFICATIONS



IMPORTANTE: NON UTILIZZARE SENZA PROTEZIONE  
IMPORTANT: DO NOT USE UNPROTECTED

- PRESSIONE NOMINALE RATED PRESSURE	350 bar – 35 MPa (5100 psi)
- PRESSIONE CONSENTITA PERMISSIBLE PRESSURE	390 bar – 39 MPa (5650 psi)
- PORTATA MASSIMA MAX FLOW RATE	40 l/min (10.5 USG p.m.)
- TEMPERATURA MASSIMA DI LAVORO (UTILIZZO CONTINUO) MAX WORKING TEMPERATURE (CONTINUOUS USE)	90° C (194°F)
- TEMPERATURA MASSIMA AMMESSA (SOLO PER BREVI PERIODI) MAX PERMISSIBLE TEMPERATURE (FOR SHORT PERIODS ONLY)	120° C (250°F)
- MATERIALE MATERIAL	CORPO IN OTTONE NICHELATO, PERNO IN ACCIAIO INOX NICKEL PLATED BRASS BODY, STAINLESS STEEL PIN
- GUARNIZIONI SEALS	TENUTE IN MATERIALE CERAMICO; OR TENUTA ACQUA IN FKM (VITON); OR TENUTA GRASSO IN FKM (VITON) E SILICONE SEALS MADE OF CERAMIC MATERIAL; O-RING WATER SEALS IN FKM (VITON); O-RING GREASE SEALS IN FKM (VITON) AND SILICON
- CUSCINETTI BEARINGS	N.2 CUSCINETTI A SFERE IN ACCIAIO INOX AUTOLUBRIFICANTI A TENUTA STAGNA NR. 2 SELF LUBRICATED WATER TIGHT SST BALL BEARING

## MISURE D'INGOMBRO – OVERALL DIMENSIONS

VISTA DA A



TABELLA SCELTA UGELLI  
NOZZLE CHART

VELOCITA' DI ROTAZIONE / PORTATA  
R.P.M / FLOW

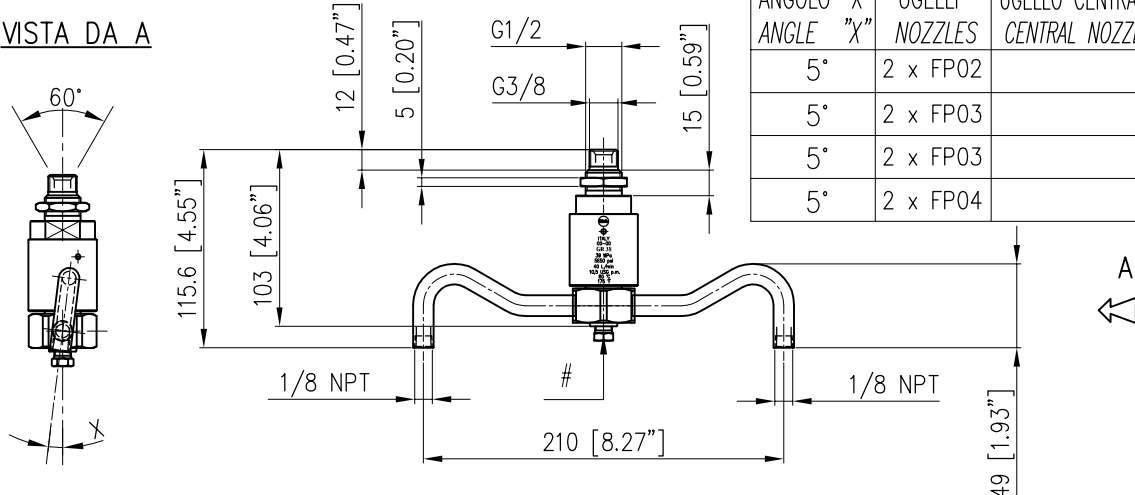
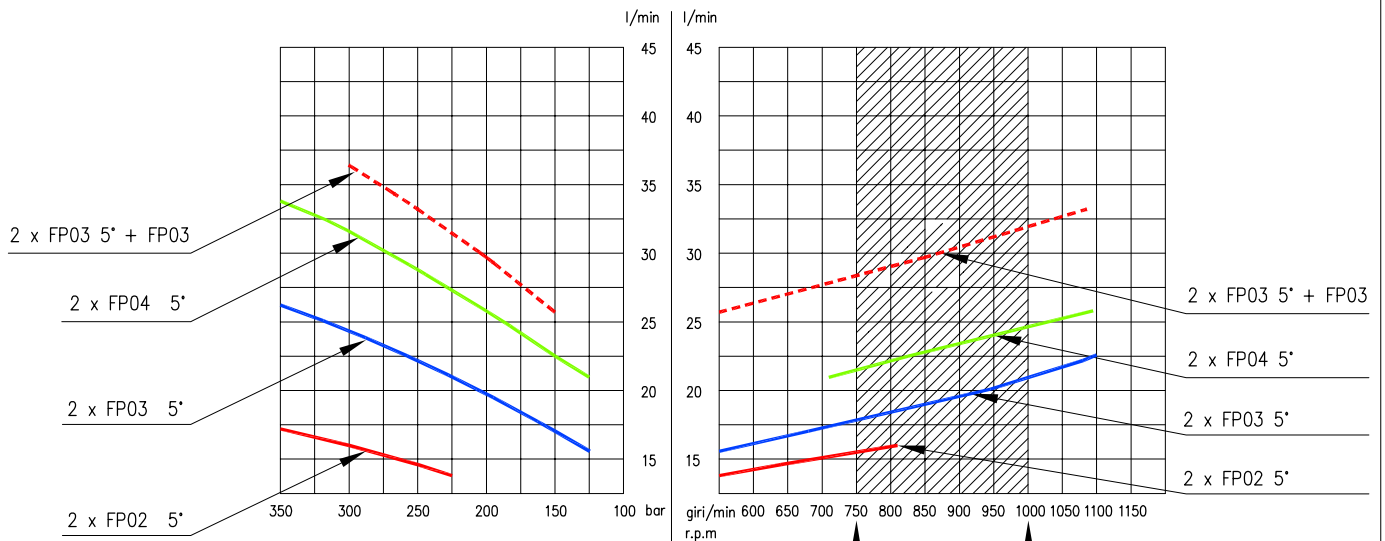

VELOCITA' DI ROTAZIONE OTTIMALE – OPTIMAL ROTATING SPEED

E  
 T  
 L  
 EQUIPAGGIAMENTI  
 TECNICI  
 AVAGGIO

26.1440.00  
 GR 38/400

### CARATTERISTICHE TECNICHE – SPECIFICATIONS



IMPORTANTE: NON UTILIZZARE SENZA PROTEZIONE  
 IMPORTANT: DO NOT USE UNPROTECTED

- PRESSIONE NOMIALE RATED PRESSURE	350 bar – 35 MPa (5100 psi)
- PRESSIONE CONSENTITA PERMISSIBLE PRESSURE	390 bar – 39 MPa (5650 psi)
- PORTATA MASSIMA MAX FLOW RATE	40 l/min (10.5 USG p.m.)
- TEMPERATURA MASSIMA DI LAVORO (UTILIZZO CONTINUO) MAX WORKING TEMPERATURE (CONTINUOUS USE)	90° C (194°F)
- TEMPERATURA MASSIMA AMMESSA (SOLO PER BREVI PERIODI) MAX PERMISSIBLE TEMPERATURE (FOR SHORT PERIODS ONLY)	120° C (250°F)
- MATERIALE MATERIAL	CORPO IN OTTONE NICHELATO, PERNO IN ACCIAIO INOX NICKEL PLATED BRASS BODY, STAINLESS STEEL PIN
- GUARNIZIONI SEALS	TENUTE IN MATERIALE CERAMICO; OR TENUTA ACQUA IN FKM (VITON); OR TENUTA GRASSO IN FKM (VITON) E SILICONE SEALS MADE OF CERAMIC MATERIAL; O-RING WATER SEALS IN FKM (VITON); O-RING GREASE SEALS IN FKM (VITON) AND SILICON
- CUSCINETTI BEARINGS	N.2 CUSCINETTI A SFERE IN ACCIAIO INOX AUTOLUBRIFICANTI A TENUTA STAGNA NR. 2 SELF LUBRICATED WATER TIGHT SST BALL BEARING

### MISURE D'INGOMBRO – OVERALL DIMENSIONS

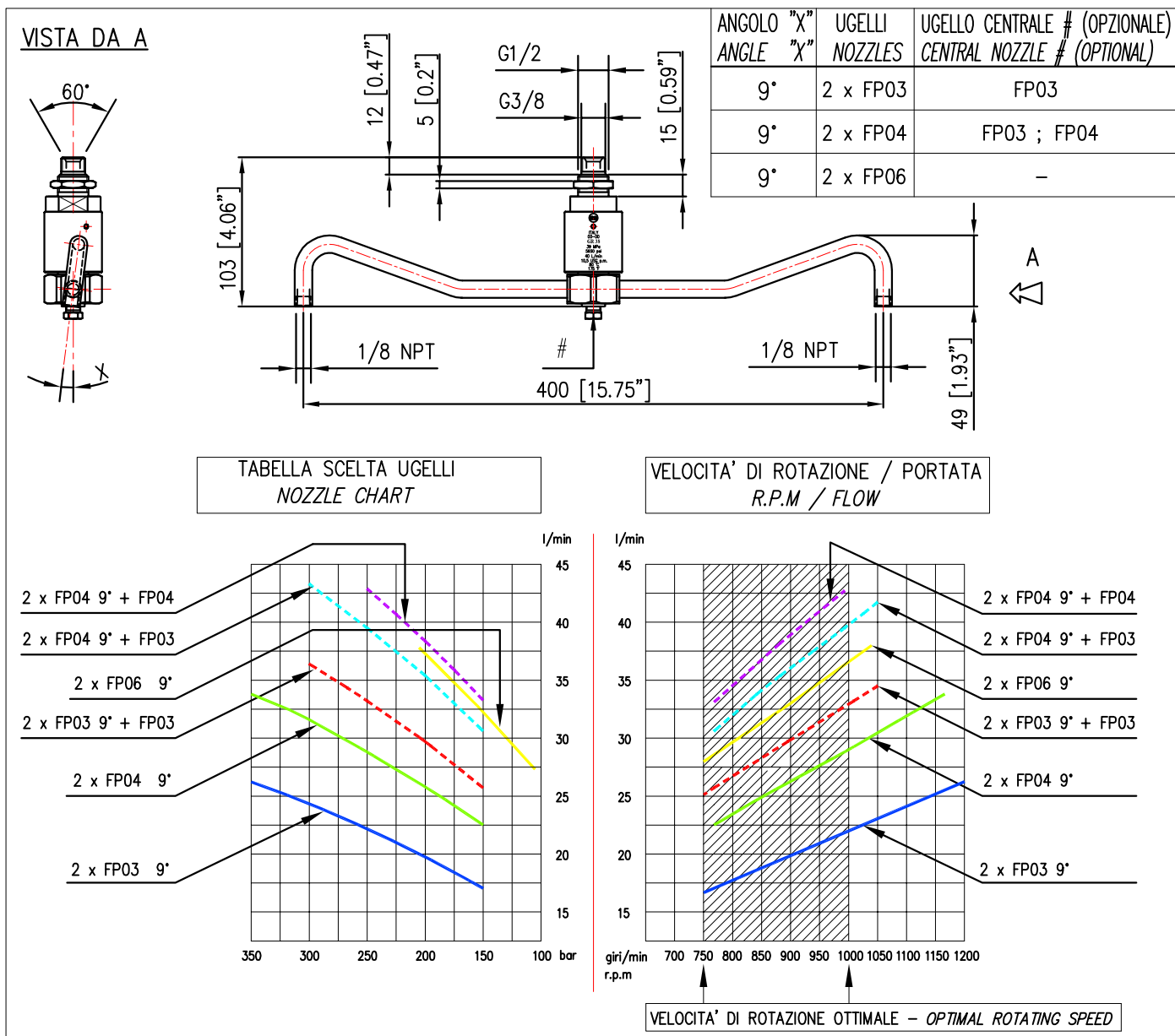

26.1420.00 GR38/200 - Testina rotante G3/8M -  
26.1440.00 GR38/400 - Test.rot. G3/8M - 2x1/8F-0,4m

26.1440.08 GR38/400/8°Testina rot.G3/8M -2x1/8Npt-400

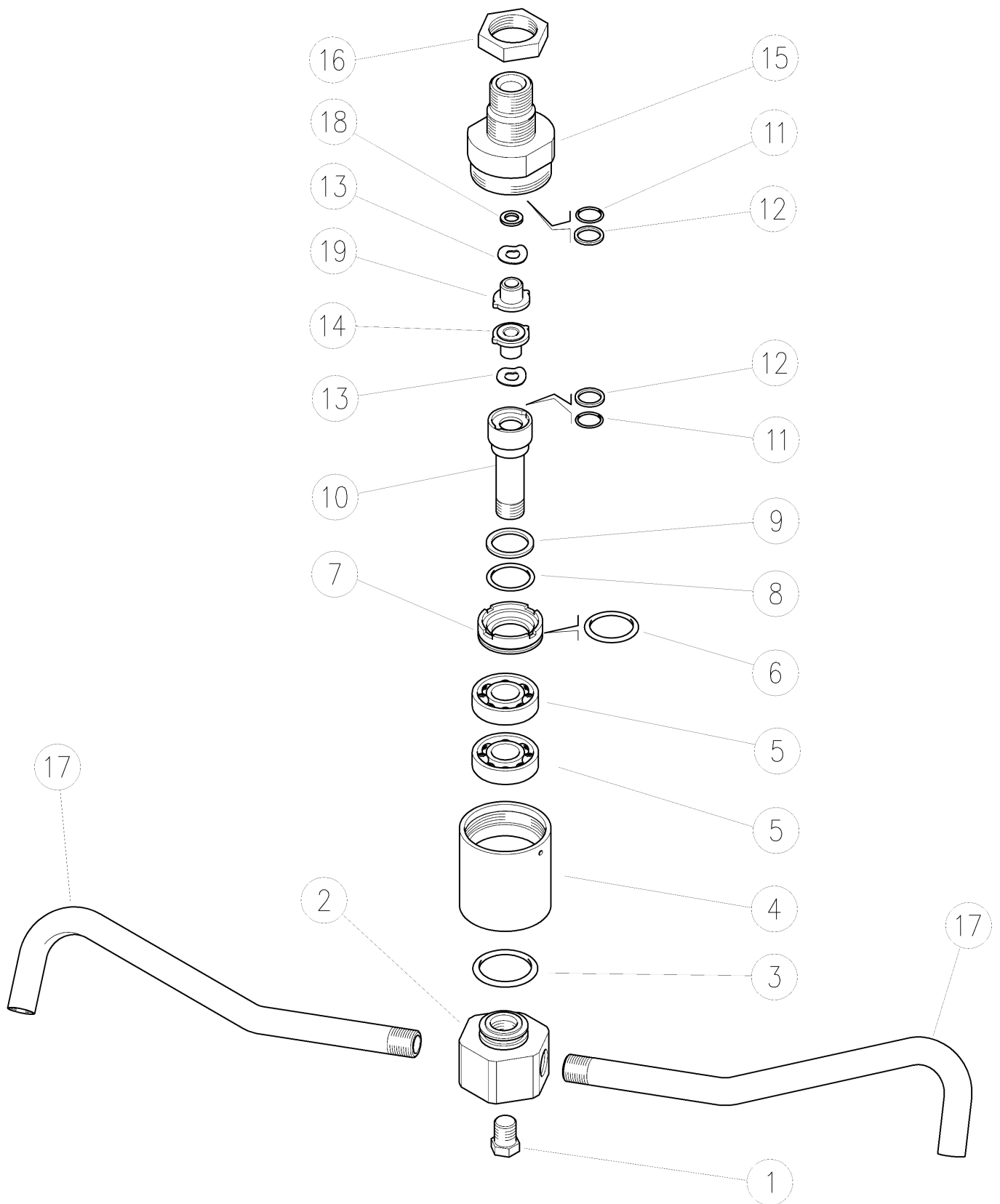

Pos.	Codice	Descrizione	Q.tà	K1	K2	K3	K4	
1	15.3711.18	Tappo inox 303 1/8M Npt s/testa	1					4
2	26.1405.31	Raccordo M12 x 1" F ottone nichelato	1					5
3	10.3180.10	An Or 2,62x15,08 mm vi.	1					10
4	26.1404.31	Corpo M30 x 1" F ottone nichelato	1					5
5	11.4410.32	Cuscinetto 12x32x10 mm inox	2					3
6	10.3077.10	An.OR 1,78x28,3 mm Vi 70	1					10
7	26.1403.31	Distanziale ottone	1					5
8	10.3068.25	An Or 1,78x17,17 mm sil.60	1					10
9	10.4012.60	An. tenuta 16,2x20,5x1,5 PTFE	1					10
10	26.1402.51	Perno rotante M12 inox	1					5

(1) 26.1440.00 (2) 26.1420.00

Pos.	Codice	Descrizione	Q.tà	K1	K2	K3	K4	
11	10.3057.10	An. OR 1,78 x 9,25 mm viton	2					10
12	10.4010.60	An.ant.es.10x12,6 mm	2					10
13	10.1110.51	Anello compensatore inox	2					5
14	26.1413.83	Anello tenuta	1					3
15	26.1401.31	Raccordo G3/8-G1/2	1					5
16	29.0175.31	Dado G1/2F ott.	1					10
17	26.1441.56	Tubo 234mm cur. 1/8Npt F-M12 inox (1)	2					5
17	26.1421.56	Tubo 134mm curvo 1/8Npt F- M12 in. (2)	2					5
18	14.3564.00	Rosetta 5,3x9,5x1mm ott.	1					10
19	26.1406.83	Anello tenuta	1					3

26.1420.00 GR38/200 - Rotating Head, 3/8M - 2x1/8FBsp  
26.1440.00 GR38/400 - Rotating Head, 2x1/8FNpt -400m

26.1440.08 GR38/400/8° - Rotating Head, 2x1/8FNpt

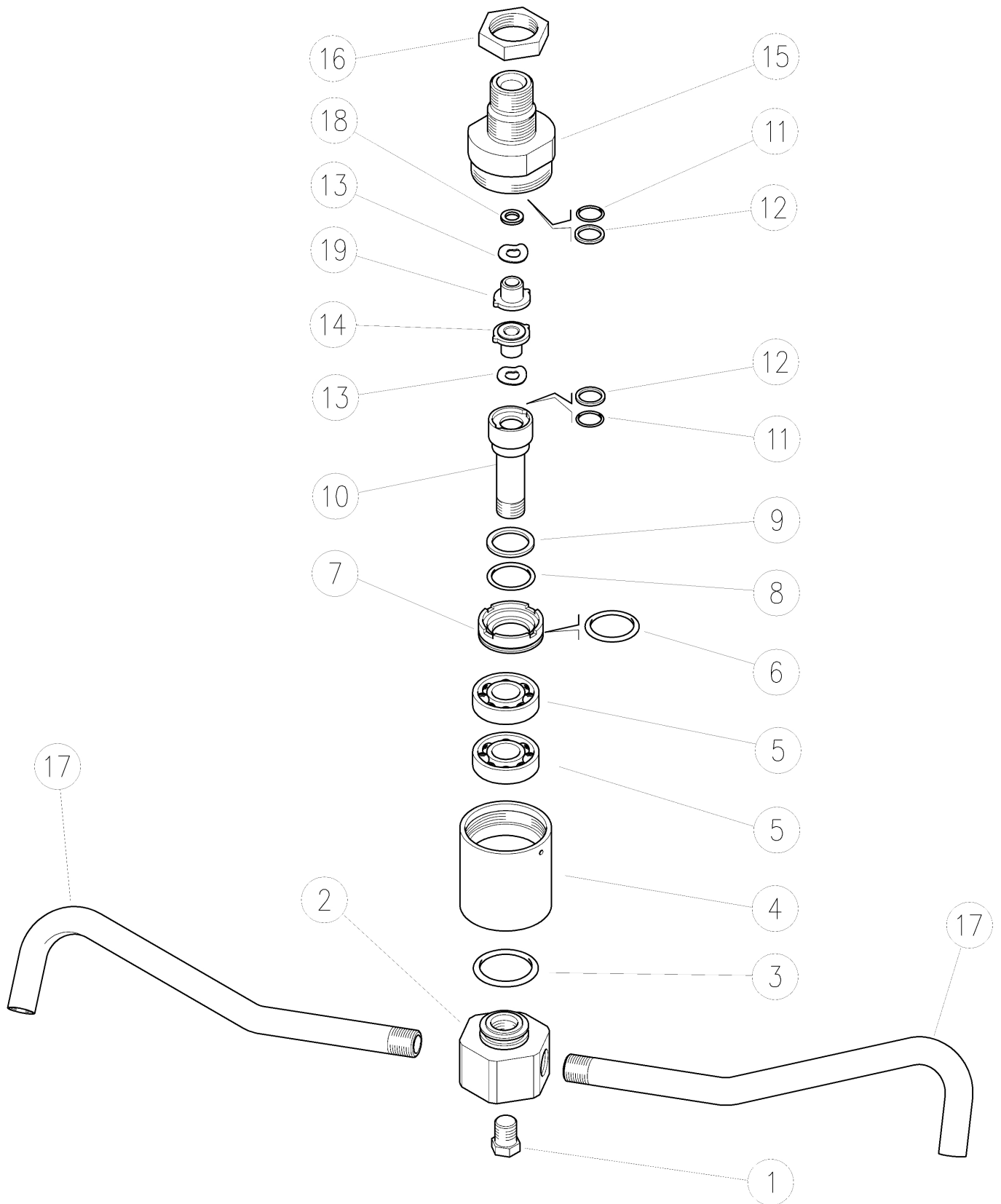

Pos.	P/N	Description	Q.ty	K1	K2	K3	K4	
1	15.3711.18	Grub screw, 303 Sst. 1/8M Npt	1					4
2	26.1405.31	Fitting, M12 x 1" F nickel-plated brass	1					5
3	10.3180.10	O-ring, 2,62x15,08 mm vi.	1					10
4	26.1404.31	Body, M30 x 1" F nickel-plated brass	1					5
5	11.4410.32	Sst.ball-bearing, 12x32x10 mm	2					3
6	10.3077.10	O-ring, 1,78x28,3 mm Vi 70	1					10
7	26.1403.31	Spacer ring, brass	1					5
8	10.3068.25	O-Ring, 1,78x17,17 mm s.	1					10
9	10.4012.60	Seal Ring 16,2x20,5x1,5 PTFE	1					10
10	26.1402.51	Rotating pin, M12, stainless steel	1					5

(1) 26.1440.00 (2) 26.1420.00

Pos.	P/N	Description	Q.ty	K1	K2	K3	K4	
11	10.3057.10	O-Ring 1,78 x 9,25 mm Viton	2					10
12	10.4010.60	Back-up ring, opn. 10x12,6x1,2 mm	2					10
13	10.1110.51	Sst ring	2					5
14	26.1413.83	Seat	1					3
15	26.1401.31	Coupling, 3/8-1/2 Bsp- brass	1					5
16	29.0175.31	Nut, 1/2F Bsp brass	1					10
17	26.1441.56	Sst.tube 234mm bent 1/8Npt F - M12 (1)	2					5
17	26.1421.56	Sst.tube 134mm bent 1/8Npt F - M12 (2)	2					5
18	14.3564.00	Washer, 5,3x9,5x1 mm brass	1					10
19	26.1406.83	Seat	1					3





P.A. S.p.A.

Via Milano, 13  
42048 Rubiera, Reggio Emilia - Italy

Tel +39.0522.623611  
Fax +39.0522.629600

info@pa-etl.it

[www.pa-etl.it](http://www.pa-etl.it)



COMPANY WITH QUALITY MANAGEMENT  
SYSTEM CERTIFIED BY DNV  
= ISO 9001 =